

**Generator set**  
**Sound-proof type**  
**WPS20S**

# **SPECIFICATIONS**

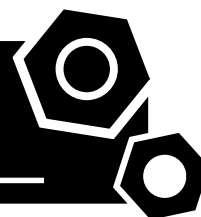

## 1 Standards & Conditions

### Design Standards

The designs and the productions are in conformity with:

- Conformance European (CE)
- China Compulsory Certification (CCC)
- ISO8528-5:2005
- GB/T2820.5-2009

### Environmental Operating Conditions

- Installation place: Outdoors or indoors (well ventilated).
- Ambient temperature: -25°C to 45°C. The coolant heater is needed when the temperature is below 5°C
- Humidity: Less than 80%.
- Altitude: Below one thousand (1000) meters.

### Factory Inspection

- Inspection items.
- Protection devices working test.
- Starting ability in normal temperature.
- 50% rated power load moment capability.
- Voltage deviation and speed variation: 0%, 25%, 50%, 75%, 100%, 110% Load.

### Painting Process

- Painting process specifications and colors are based on the manufacturer's standard.
- The customer could also choose the color which the manufacturer offers.

## 2 General Features

- Perkins engine 404D-22G
- Close coupled to a Stamford alternator PI144D
- Microprocessor control module PLC-7320
- SCHNEIDER main circuit breaker: 3-Phase 32A
- Rotate speed governor: Mechanical governor
- Excitation System: Self excited
- A.V.R.Model: AS480
- Key switch
- Emergency stop switch
- ATS (automatic transfer switch) receptacle
- 1x12V sealed for life maintenance free battery

- Lockable battery isolator switch
- Powder coated canopy
- 50°C radiator
- Oil pump on the engine
- Steel base frame with forklifts
- Vibration isolators between the engine/alternator and base frame
- Dry type air filter
- Base fuel tank for 24 hours running
- Drain points for fuel tank
- Operation Manual / Specifications

## 3 Equipment Specification

### General technical data

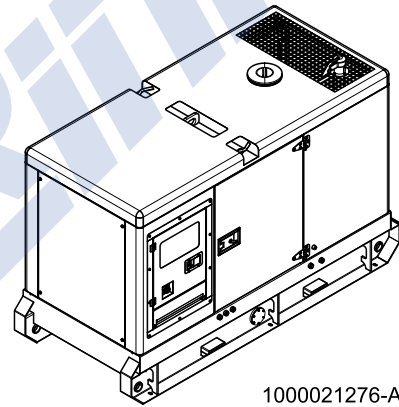

1000021276-AP1-B2

Model.....	WPS20S
Structure type .....	R
Tank capacity.....	140L
Dry weigh.....	1036kg
Noise level @7m .....	N/A
Dimensions L×W×H.....	2192×1013×1470.5mm
Standby Power .....	21.5kVA/17.2kW
Prime Power.....	20kVA/16kW

Voltage	380V	400V	415V	440V	
Ampere	30.4A	28.9A	27.8A	26.2A	
Genset Fuel Consumption					
Frequency/Load	25%	50%	75%	100%	110%
50Hz (L/h)	N/A	2.9	4.0	5.3	6.1

## Diesel Engine

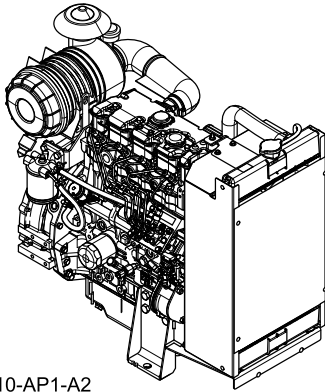

1000090010-AP1-A2

Engine Manufacturer/Brand.....	Perkins
Engine Model.....	404D-22G
Dimensions L×W×H.....	915×477×840mm
Dry Weigh (approx.).....	242kg
Number of Cylinders.....	4
Bore.....	84mm
Stroke.....	100mm
Displacement.....	2.216L
Compression Ratio.....	23.3
Type of injection.....	Indirect injection
Intake System.....	Natural aspirated
Intake Resistance.....	≤6.4kPa
Cooling System.....	Water cooled
Fan.....	Pusher
Battery Voltage.....	12V
Type of Fuel.....	EPA2D 89.330-96/CEC RF-06-99
Type of Oil.....	API-CH-4/ ACEA E5
Oil Capacity.....	10.6L
Type of Coolant.....	Glycol mixture
Coolant Capacity.....	7.0L
Back Pressure.....	≤10.2kPa
Standby Power.....	20.6kW
Prime Power.....	18.7kW
Fuel Consumption(100%load).....	243g/kWh

## Alternator

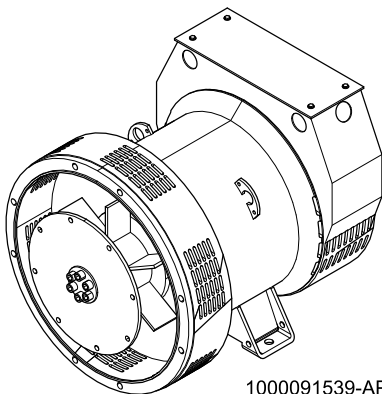

1000091539-AP1-A1

Alternator Manufacturer/Brand.....	Stamford
Alternator Model.....	PI144D
Exciter.....	Brushless
Cooling Fan.....	Plastic
Windings.....	100% copper
Insulation Class.....	H
Winding Pitch.....	2/3
Terminals.....	12
Drip Proof.....	IP23
Altitude.....	≤1000m
Overspeed.....	2250rpm
Air Flow.....	0.10 m³/s(50Hz),0.122m³/s(60Hz)
Voltage Regulation.....	±1.0 %
Total harmonic TGH / THCat no load < 1.5 % - on load < 5%	
Telephone Interference.....	THF<2%;TIF<50

## PLC-7320 Control System

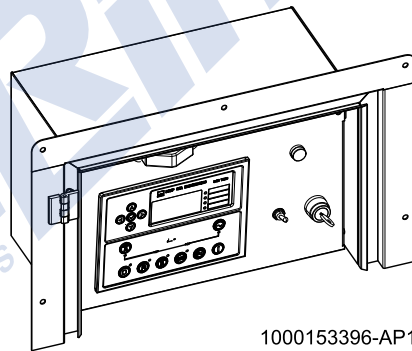

1000153396-AP1-A1

PLC-7320 is an advanced control module based on micro-processor, containing all necessary functions for protection of the genset and the breaker control. It can monitor the mains supply, and automatically start the engine when the mains is abnormal. Accurately measure various operational parameters and display all values and alarms information on the LCD. In addition, the control module can automatically shut down the engine and indicate the engine failure.

- Microprocessor control, with high stability and credibility
- Monitoring and measuring operational parameters of the mains supply and genset
- Indicating operation status, fault conditions, all parameters and alarms
- Multiple protections; multiple parameters display, like pressure, temp. etc.
- Manual, automatic and remote work mode selectable
- Real time clock for time and date display, overall runtime display, 250 log entries
- Overall power output display
- Integral speed/frequency detecting, telling status of start, rated operation, overspeed etc.
- Communication with PC via RS485 OR RS232 interface, using MODBUS protocol

## 4 Overall Dimensions

1000021276-DR1-B2

Dry weight	1036kg
Fuel tank capacity	140L
Dimensions L x W x H	2192x1013x1470.5mm

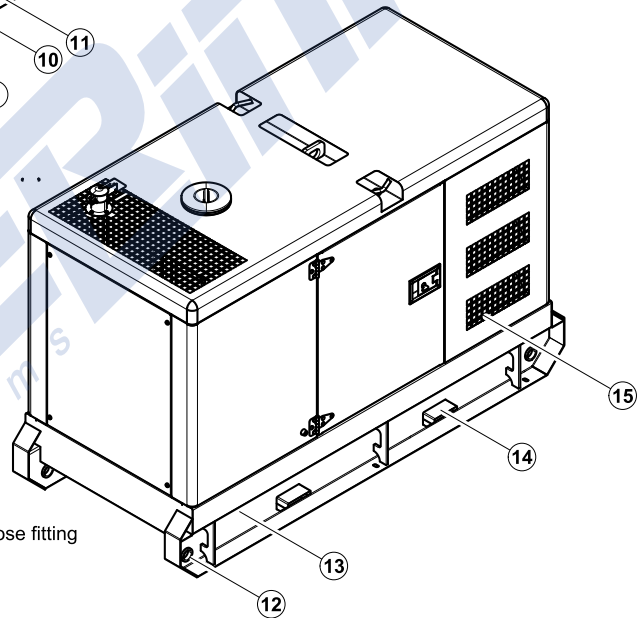
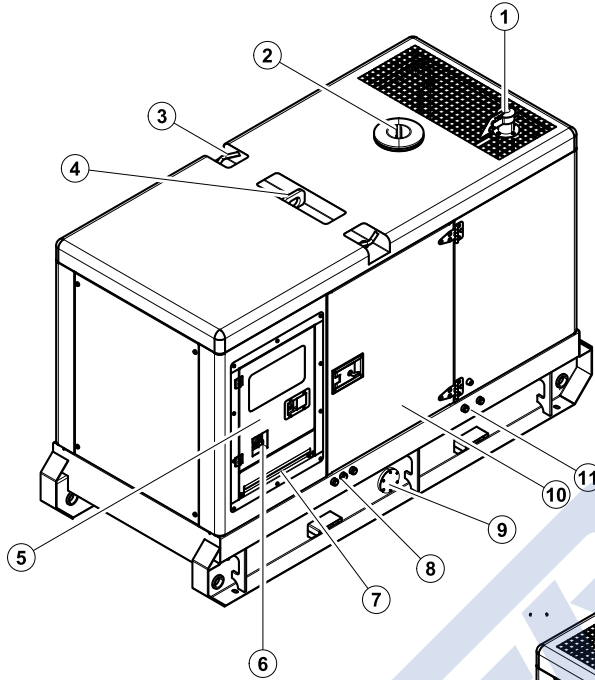

- ⑧ Oil/coolant drain hose fitting
- ⑦ Cable trench
- ⑥ Emergency stop switch
- ⑤ Control cabinet
- ④ Lifting lug
- ③ Roping lug
- ② Coolant inlet
- ① Exhaust gas outlet
- ⑮ Air inlet
- ⑭ Fork lift channel
- ⑬ Base frame
- ⑫ Tie down
- ⑪ External fuel inlet/return hose fitting
- ⑩ Access door
- ⑨ Fuel drain

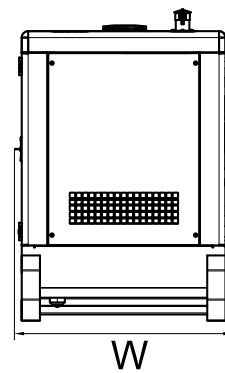
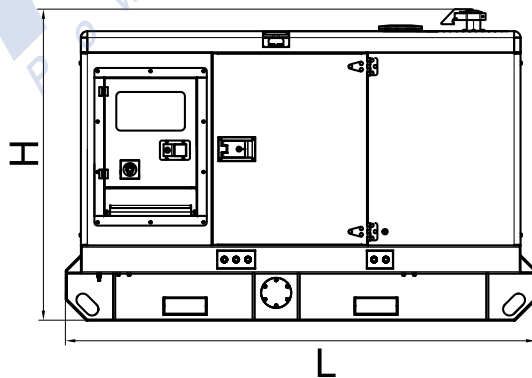

## 5 Control System

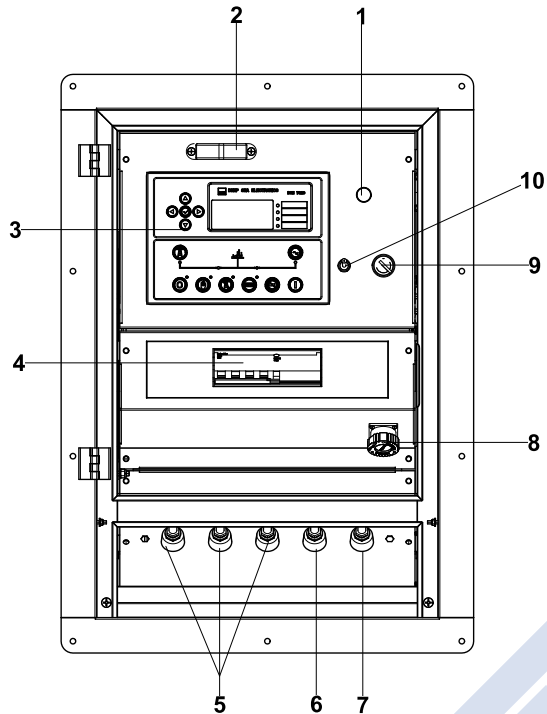

Ref.	Description
1	Charge indicator
2	Control cabinet lamp
3	Control module
4	Main circuit breaker
5	Live wire terminals
6	Neutral wire terminal
7	Ground wire terminal
8	Mains input/remote/AMF communication connector
9	Key switch
10	Control cabinet lamp switch

**Control & field wiring cabinet**

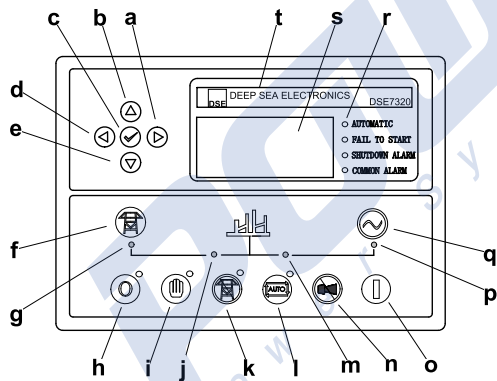

**Control Panel**

a	Button (next page)
b	Button (increase value / previous item)
c	Button (accept)
d	Button (previous page)
e	Button (decrease value / next item)
f	Button (transfer the load to the mains supply, when in Manual mode only)
g	Mains supply available LED
h	Stop / Reset button
i	Manual button (Manual control mode)
j	Mains supply on load LED
k	Test button (Test mode)
l	Auto button (Auto mode)
m	Genset on load LED
n	Mute/Lamp test button
o	Start button (Manual)
p	Genset available LED
q	Button (transfer the load to the genset, when in Manual mode only)
r	Alarm LED (4 alarm items)
s	LCD display
t	Control module name

100021276-B2-E
----------------

03.2012
---------

**POWERLINK**<sup>®</sup>  
Power Systems

<http://www.powerlinkworld.com>

*Specification may change without prior notice. For more info.,  
contact Power Link or your local distributors please.*