

Generator set
Sound-proof type
GMS150CS

SPECIFICATIONS

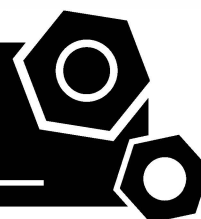

EC series GMS150CS



50 Hz @ 1500rpm,3-phase/5-wiring

1 Standards & Conditions

Design Standards

The designs and the productions are in conformity with:

- Conformance Europeenne (CE)
- ISO8528-5:2005
- GB/T2820.5-2009

Environmental Operating Conditions

- Installation place: Outdoors or indoors (well ventilated).
- Ambient temperature: -25°C to 50°C. The coolant heater is needed when the temperature is below 5°C
- Humidity: Less than 80%.
- Altitude: Below one thousand (1000) meters.

Factory Inspection

- Inspection items.
- Protection devices working test.
- Starting ability in normal temperature.
- 50% rated power load moment capability.
- Voltage deviation and speed variation: 0%, 25%, 50%, 75%, 100%, 110% Load.

Painting Process

- Painting process specifications and colors are based on the manufacturer's standard.
- The customer could also choose the color which the manufacturer offers.

2 General Features

- Cummins engine 6BTAA5.9-G12
- Close coupled to LSA alternator LSA44.3L10
- Microprocessor control module PLC-920
- Main circuit breaker: 250A
- Rotate speed governor: EFC
- Excitation system: Self excited
- A.V.R model: R250
- Key switch
- Emergency stop switch
- ATS (automatic transfer switch) receptacle
- 2x12V/120AH Sealed for life maintenance free battery

- Lockable battery isolator switch
- 50°C radiator
- Oil pump on the engine
- Steel base frame with lifting lugs
- Vibration isolators between the engine/alternator and base frame
- Dry type air filter
- Base fuel tank for 9 hours running
- Drain points for fuel tank
- Operation Manual / Specifications

3 Equipment Specification

General technical data

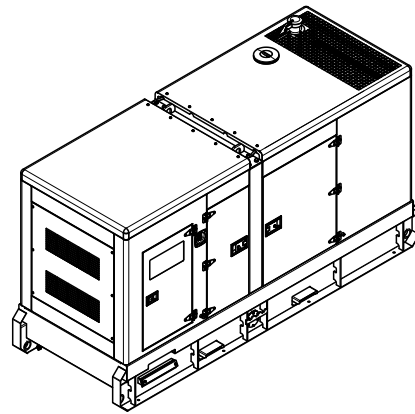

Model..... GMS150CS
 Structure type R
 Tank capacity.....300L
 Dry weight.....2303kg
 Noise level @7m 71.6dBA
 Dimensions L×W×H..... 3308x1150x1837mm
 Standby Power 165kVA/132kW
 Prime Power 150kVA/120kW

Voltage	380V	400V	415V	440V	
Ampere	227.9A	216.5A	208.7A	196.8A	
Genset Fuel Consumption					
Frequency/Load	25%	50%	75%	100%	110%
50Hz (L/h)	10	17	26	34	38

Dck Yf' GrghYa

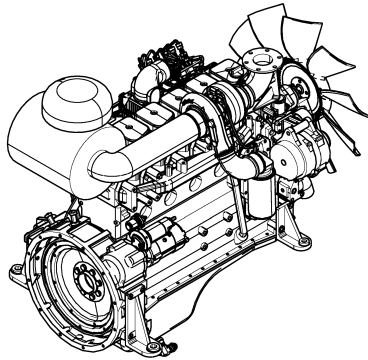

Engine Manufacturer/Brand	Cummins
Engine Model	6BTAA5.9-G12
Dimensions L×W×H.....	1215.8*730.5*1153.6
Dry Weigh (approx.)	653kg
Number of Cylinders	6
Bore	102mm
Stroke	120mm
Displacement.....	5.9L
Compression Ratio	17.3
Type of injection.....	Direct injection
Intake System.....	Turbocharged,water-to-air charge cooled
Intake Resistance	≤6.28kPa
Cooling System	Water cooled
Fan	Pusher
Battery Voltage	12/24V
Type of Fuel.....	Diesel
Type of Oil	ACEA E2, API CF, CF-4, CG-4
Oil Capacity	16.4L
Type of Coolant	Glycol mixture
Coolant Capacity	10.0L
Back Pressure	≤10.1kPa
Standby Power	140kW
Prime Power	155kW
Fuel Consumption(100%load)	203g/kW.h

Alternator

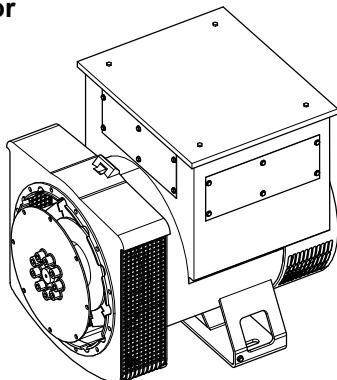

Alternator Manufacturer/Brand	LSA
Alternator Model	LSA44.3L10
Exciter.....	Brushless
Cooling Fan	Cast alloy aluminum
Windings.....	100% copper
Insulation Class	H
Winding Pitch.....	2/3
Terminals	12
Drip Proof	IP23
Altitude.....	≤1000m
Overspeed	2250 rpm
Air Flow.....	0.216m³/s(50HZ),0.281m³/s(60HZ)
Voltage Regulation	±1.0%
Total harmonic TGH / THCat no load < 1.5 % - on load < 5%	
Telephone Interference.....	THF<2%;TIF<50

PLC-920 Control System

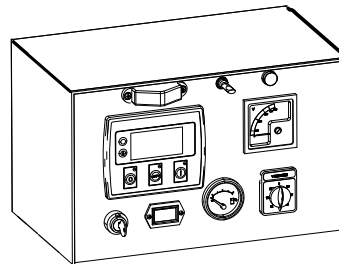

PLC-920 is an advanced control module based on micro-processor designed to control the engine via a key switch and push buttons on the front panel. The module is used to start and stop the engine and indicate fault conditions, automatically shutting down the engine and giving a true up fault condition of an engine failure.

Standard Control Function

- Manual Engine Control Module
- Low Oil Pressure
- High Engine Temperature
- Auxiliary Shutdown
- Overspeed Protection
- Protection hold-off timer
- Charge Failure warning

4 Overall Dimensions

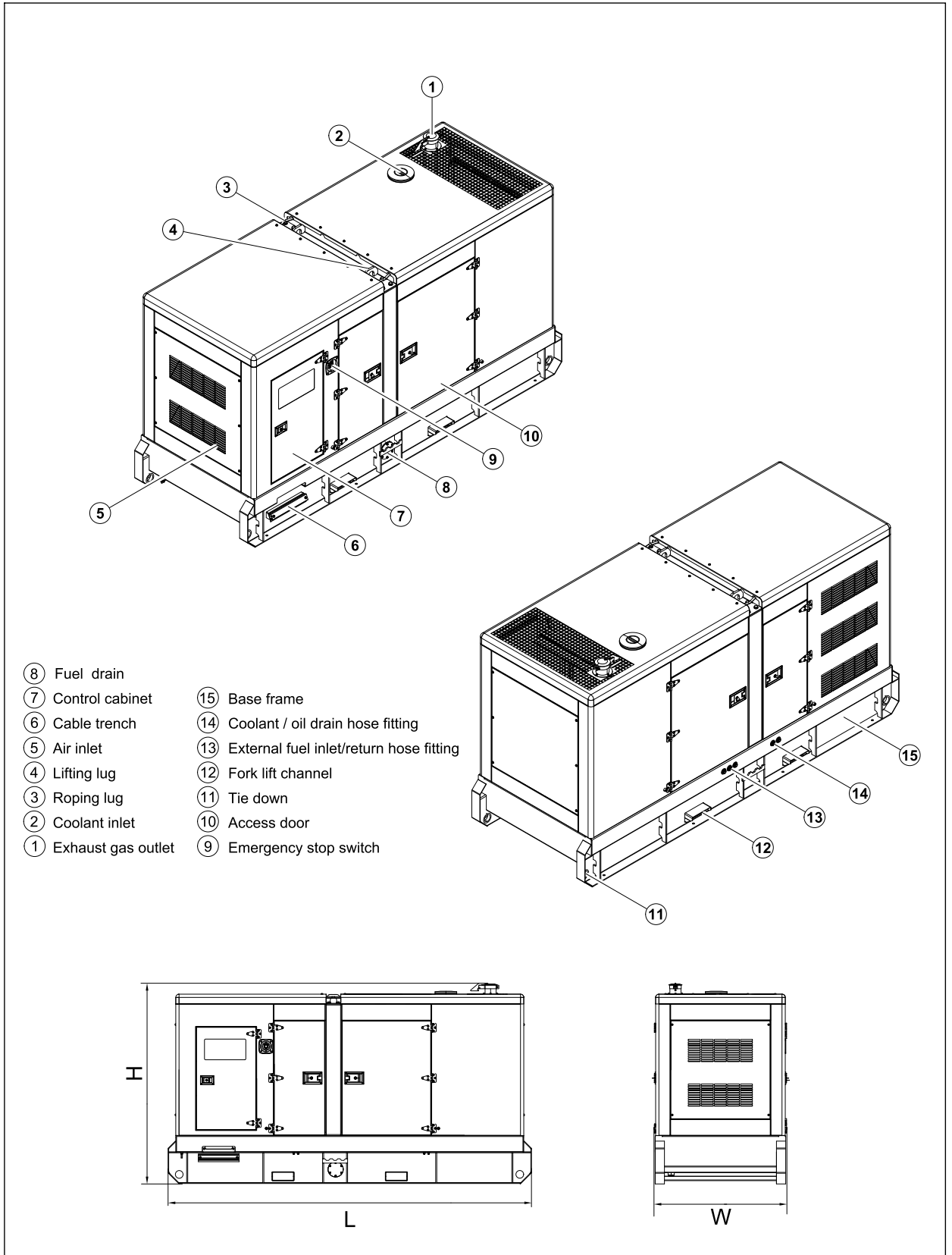

5 Control System

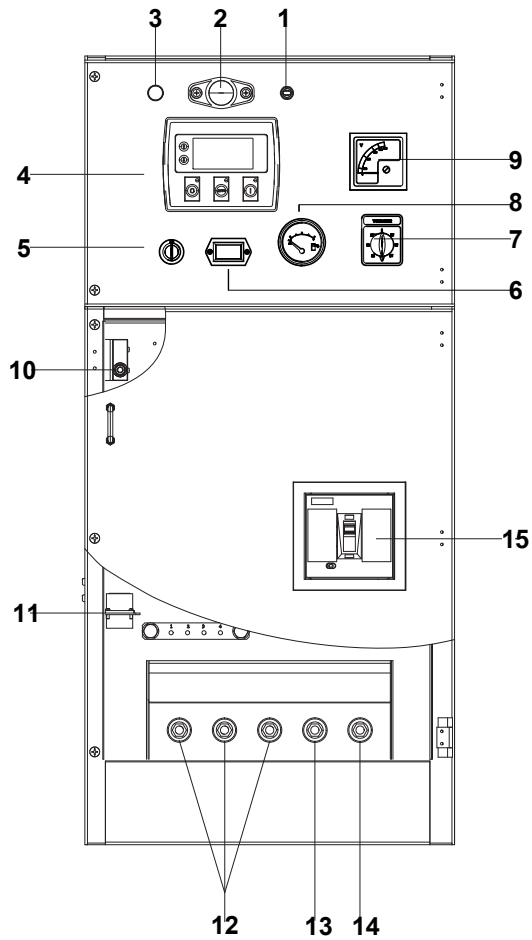

Control & field wiring cabinet

Ref.	Description
1	Control cabinet lamp switch
2	Control cabinet lamp
3	Charge indicator
4	Control module
5	Key switch
6	Time counter
7	Voltage changer-over switch
8	Fuel level meter
9	Voltage meter
10	Limit switch
11	Mains input/Remote control/ATS connector
12	Live wire terminal
13	Neutral wire terminal
14	Ground wire terminal
15	Main circuit breaker

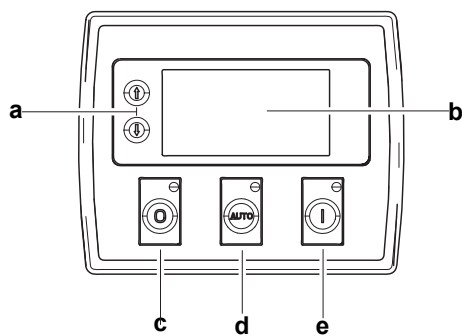

Control module

Ref.	Description
a	Navigation button«» Accept (Configuration mode only)
b	Main status display
c	Stop/reset button«» Next page (Configuration mode only)
d	Auto start button«» Decrease value/next item (Configuration mode only)
e	Start button«» Increase value/next item (Configuration mode only)

1000029546-A2-E

08.2023

<http://www.powerlinkworld.com>

*Specification may change without prior notice. For more info.,
contact Power Link or your local distributors please.*