

**Generator set**

**Containerized type**

**HVC1875S**

# **SPECIFICATIONS**

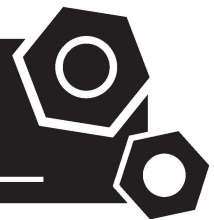

# HV series HVC1875S

50 Hz @ 1500rpm, 10500V



## 1 Standards & Conditions

### Design Standards

The designs and the productions are in conformity with:

- Conformance Européenne (CE)
- ISO8528-5:2005
- GB/T2820.5-2009

### Environmental Operating Conditions

- Installation place: Outdoors or indoors (well ventilated).
- Ambient temperature: -25°C to 50°C. The coolant heater is needed when the temperature is below 5°C
- Humidity: Less than 80%.
- Altitude: Below one thousand (1000) meters.

### Factory Inspection

- Inspection items.
- Protection devices working test.
- Starting ability in normal temperature.
- 50% rated power load moment capability.
- Voltage deviation and speed variation: 0%, 25%, 50%, 75%, 100%, 110% Load.

### Painting Process

- Painting process specifications and colors are based on the manufacturer's standard.
- The customer could also choose the color which the manufacturer offers.

## 2 General Features

- Cummins engine QSK60-G3
- Close coupled to Leroy Somer alternator LSA53.2VL6
- Microprocessor control module PLC-500
- HV Switchgear Panel (optional) : ABB 630A
- PT Cabinet (optional)
- DC Power Cabinet (optional)
- Rotate speed governor: Electrical governor
- Excitation System: AREP
- A.V.R. Model: R448
- Key switch
- Emergency stop switch

- 4x12V/200AH sealed for life maintenance free battery
- Lockable battery isolator switch
- Powder coated canopy
- 50°C radiator
- Fire extinguisher
- Heat exchanger
- Coolant heater
- Oil pump on the engine
- Steel base frame with forklots
- Vibration isolators between the engine/alternator and base frame
- Dry type air filter
- Drain points for fuel tank
- Fuel inlet pump and it's control box for the fuel tank
- Added fuel-water separator for fuel tank
- Operation Manual / Specifications

## 3 Equipment Specification

### General technical data

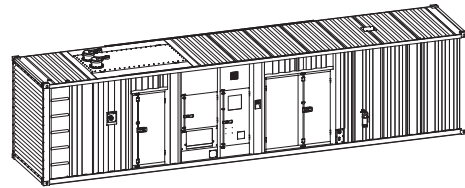

|                       |                   |
|-----------------------|-------------------|
| Model.....            | HVC1875S          |
| Structure type .....  | C                 |
| Fuel tank.....        | 2400L             |
| Dry weight.....       | 26000kg           |
| Noise level @7m ..... | 83dB              |
| Dimensions L×W×H..... | 12192x2438x3153mm |
| Standby Power .....   | 2063kVA/1650kW    |
| Prime Power.....      | 1875kVA/1500kW    |
| Voltage/Ampere .....  | 10500V/103A       |

| Genset Fuel Consumption |     |     |     |      |      |
|-------------------------|-----|-----|-----|------|------|
| Frequency/Load          | 25% | 50% | 75% | 100% | 110% |
| 50Hz (L/h)              | 114 | 196 | 276 | 371  | 408  |

## Diesel Engine

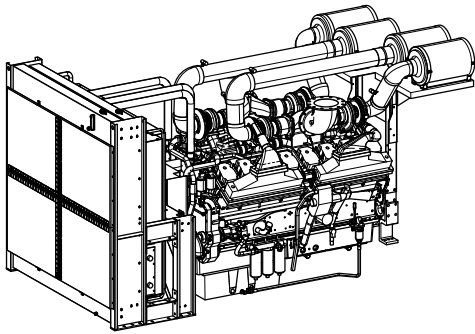

|                                |                         |
|--------------------------------|-------------------------|
| Engine Manufacturer/Brand..... | Cummins                 |
| Engine Model.....              | QSK60G3                 |
| Dimensions LxWxH.....          | 4123x2185x2410mm        |
| Dry Weigh (approx.) .....      | 7185Kg                  |
| Number of Cylinders.....       | 16                      |
| Bore.....                      | 159mm                   |
| Stroke .....                   | 190mm                   |
| Displacement.....              | 60.2L                   |
| Compression Ratio.....         | 14.5                    |
| Type of injection.....         | Direct injection        |
| Intake System.....             | Turbocharged            |
| Intake Resistance.....         | ≤6.2kPa                 |
| Cooling System .....           | Water cooled            |
| Fan .....                      | Pusher                  |
| Battery Voltage .....          | 24V                     |
| Type of Fuel.....              | No. 2 diesel or ASTM D2 |
| Type of Oil .....              | 15W40 to API CH4        |
| Oil Capacity .....             | 280L                    |
| Type of Coolant .....          | Glycol mixture          |
| Coolant Capacity .....         | 242L                    |
| Back Pressure .....            | ≤6.8kPa                 |
| Standby Power .....            | 1800kW                  |
| Prime Power .....              | 1636kW                  |

## HV Alternator

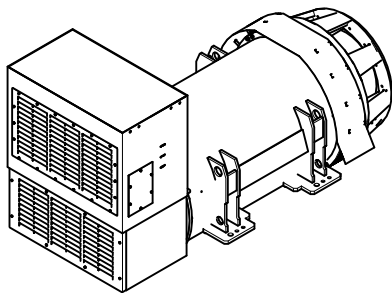

|                                     |                     |
|-------------------------------------|---------------------|
| Alternator Manufacturer/Brand ..... | Leroy Somer         |
| Alternator Model .....              | LSA53.2VL6          |
| Exciter.....                        | Brushless           |
| Cooling Fan .....                   | Cast alloy aluminum |
| Windings.....                       | 100% copper         |
| Insulation Class .....              | H                   |
| Winding Pitch.....                  | 5/6                 |
| Terminals .....                     | 6                   |
| Drip Proof .....                    | IP23                |
| Altitude.....                       | ≤1000m              |
| Overspeed .....                     | 2250rpm             |
| Air Flow.....                       | 2.5m³/s             |
| Voltage Regulation .....            | ±0.5%               |
| Total harmonic TGH / THC .....      | < 3.5%              |
| Telephone Interference.....         | FHT<2%;TIF<50       |

## PLC-500 Control System

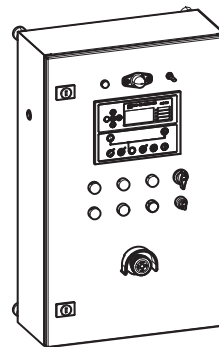

PLC-500 is a microprocessor based control unit containing all necessary functions for protection of the genset and the breaker control. Furthermore, it contains all necessary three-phase measuring circuits and presents all values and alarms on the LCD display. The module has the function of load sharing which enables the module to share the active load (kW) equally when operating in parallel with other gensets. The load sharing is performed so each genset takes a portion of the load that is calculated in percent according to the nominal power.

- Microprocessor control, with high stability and credibility
- Monitoring and measuring operational parameters of the genset
- Indicating operation status, fault conditions, all parameters and alarms
- Multiple protections; multiple parameters display, like pressure, temp. etc.
- Manual, automatic and remote work mode selectable
- RS232 & RS485 can be used at the same time
- Real time clock for time and date display, overall runtime display, 250 log entries

## 4 Overall Dimensions

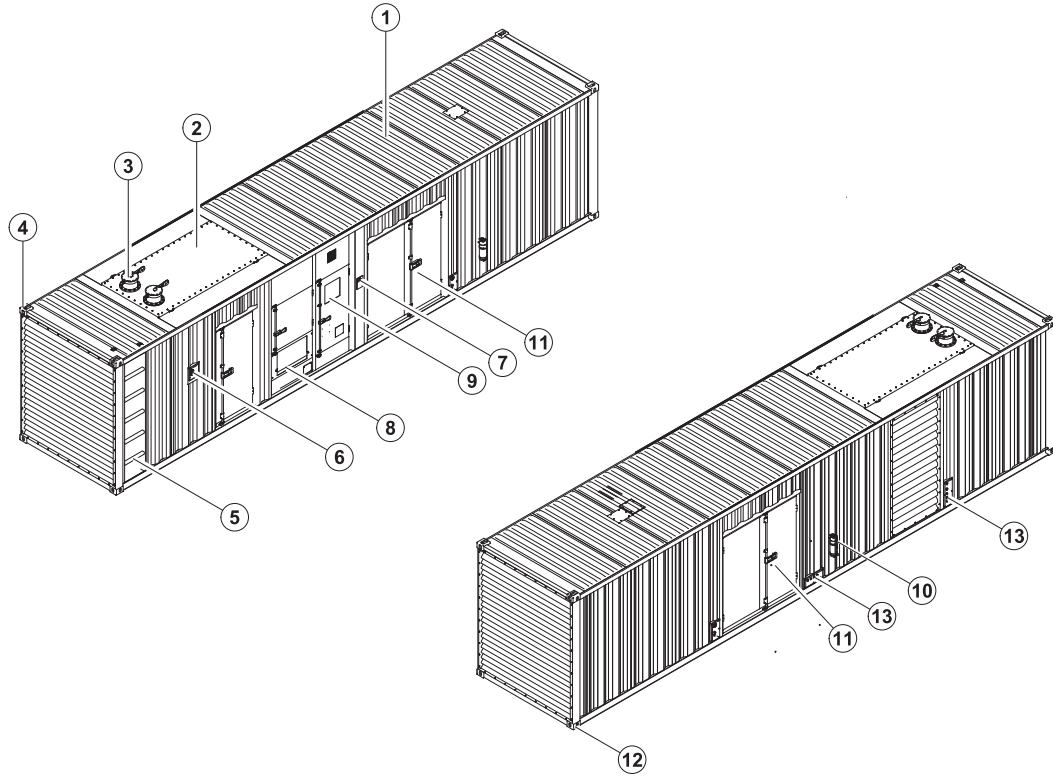

- |                         |   |
|-------------------------|---|
| ⑦ Emergency stop switch | ⑬ External fuel inlet/return hose fitting<br>Coolant/Oil drain hose fitting |
| ⑥ Fuel inlet            | ⑫ Fixing lug  |
| ⑤ Ladder                | ⑪ Access door   |
| ④ Lifting lug           | ⑩ Fire extinguisher   |
| ③ Exhaust gas outlet    | ⑨ Control cabinet   |
| ② Muffler               | ⑧ Cable trench  |
| ① Canopy                |   |

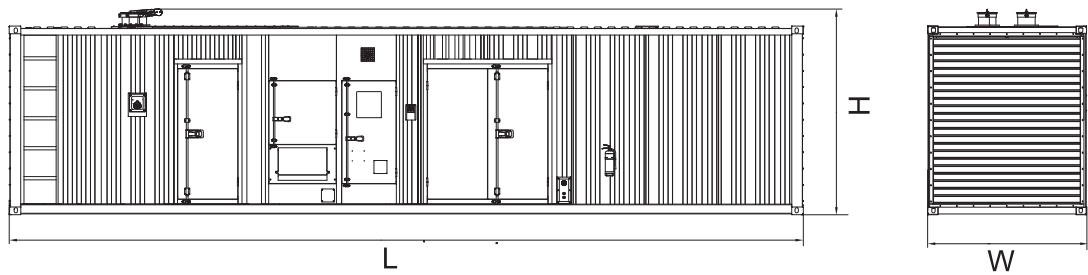

## 5 Switchgear Panel (optional)

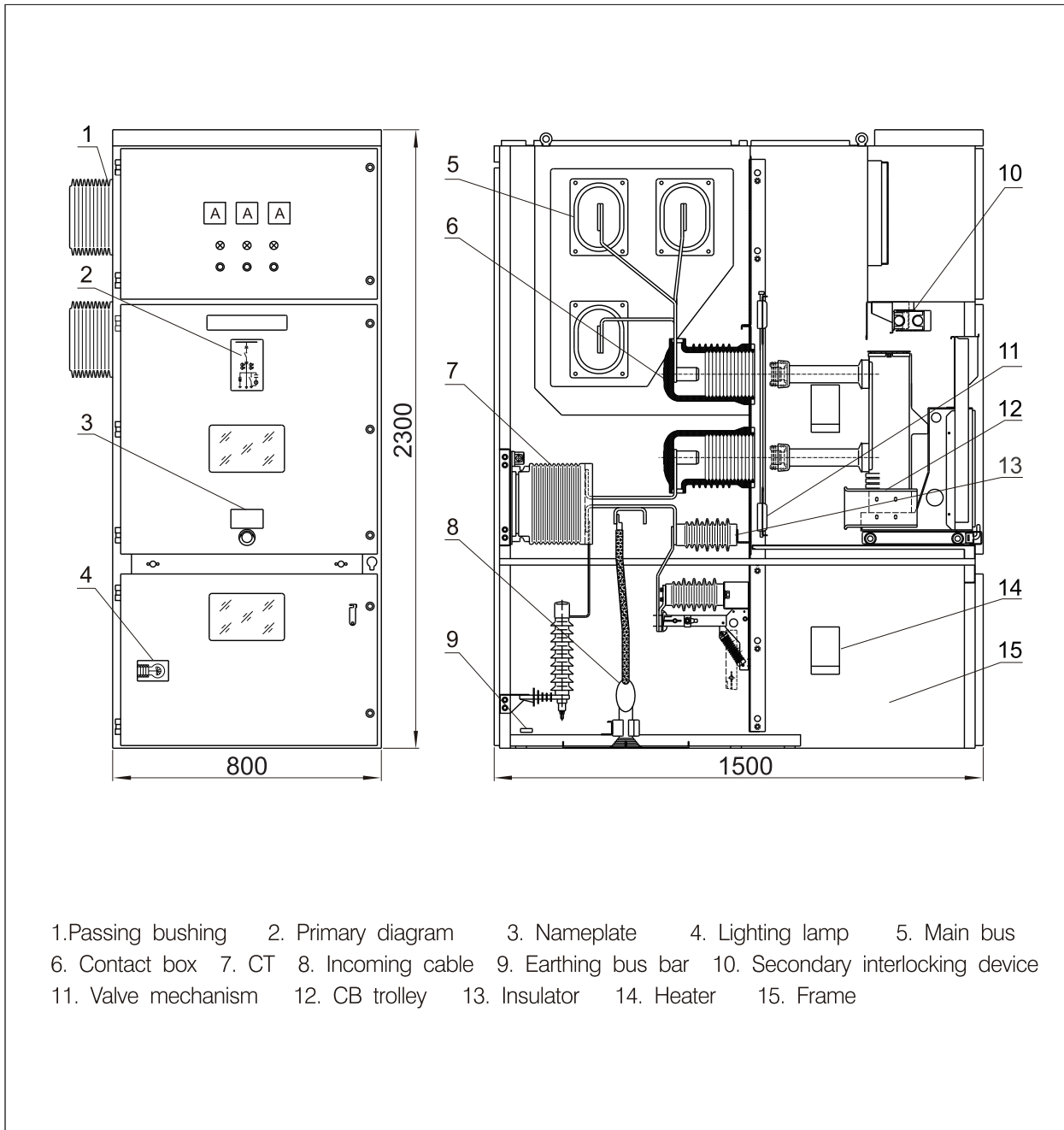

|                 |
|-----------------|
| 1000032091-A2-E |
|-----------------|

|         |
|---------|
| 09.2024 |
|---------|

<http://www.powerlinkenergy.com>

*Specification may change without prior notice. For more info.,  
contact Power Link or your local distributors please.*